

# Fontaine Fifth Wheel Ultra LT

## Rebuild Procedures

- Disassembly
- Assembly
- Adjustments

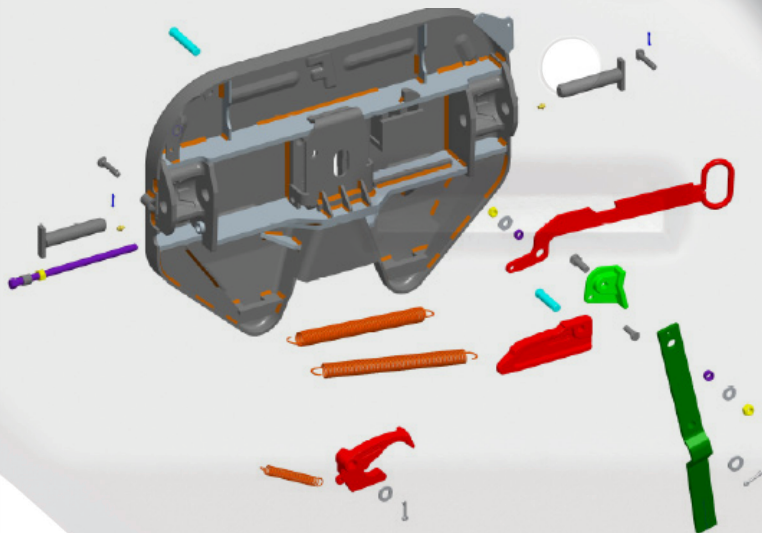

[www.fifthwheel.com](http://www.fifthwheel.com) • 800-874-9780

Cover plate removed for clarity. Refer to exploded view of assembly on page 4 to identify item number and parts.

## Degrease fifth wheel before installing new parts

### 1. Set the fifth wheel in the closed position

To set the fifth wheel in the closed position, rotate the jaw towards the front of the fifth wheel with a screw driver of adequate length to keep hands and fingers out of the throat of the wheel. This will partially close the wheel. Now pull out on the pull handle a small amount and complete the rotation of the jaw toward the front of the wheel. Allow the pull handle to go in slowly for the wheel to completely close.

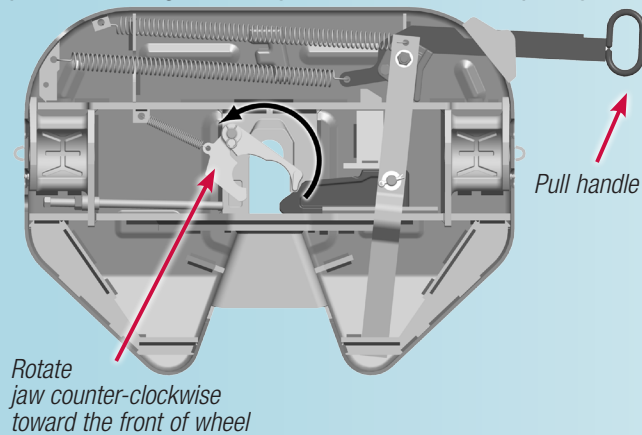

### 2. Remove the jaw spring

Remove the jaw spring (item 27). Now remove the main spring (item 26) from the pull handle. Remove the main spring (item 26) from the operating handle.

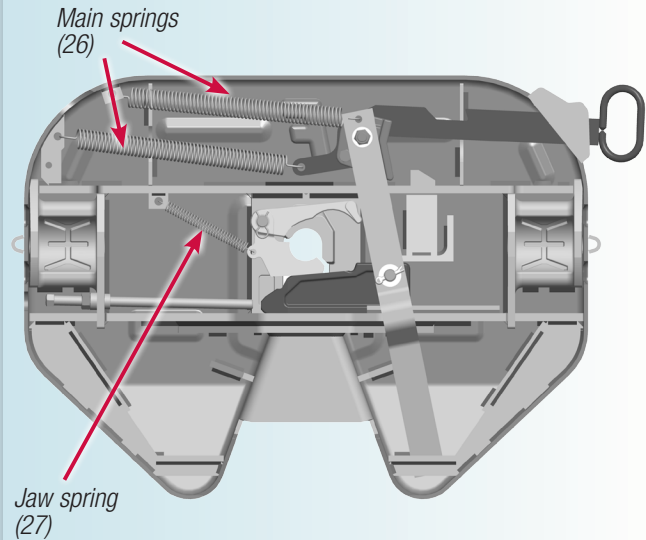

### 3. Move operating lever to open wheel.

Pull the handle to open the wheel to move the lockbar from behind jaw. It may be necessary to rotate the secondary lock to clear the lock stop.

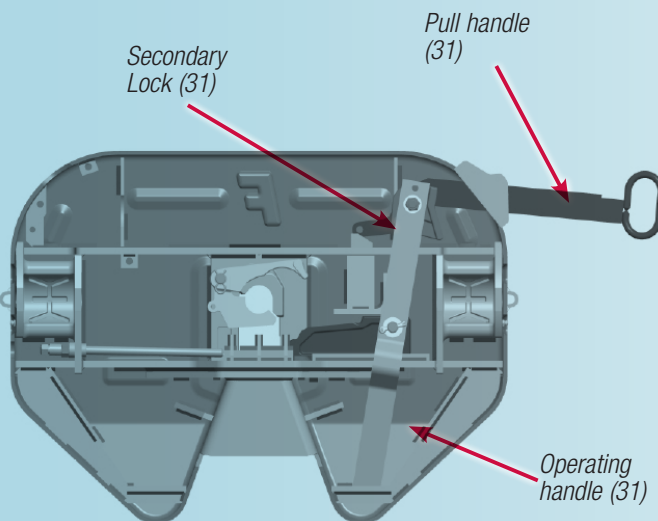

### 4. Remove the rotating locking jaw

Remove the pivot pin clip (item 29) from the long pivot pin (item 7). Raise the top plate and remove the long pivot pin (item 7) that secures the rotating locking jaw (item 28). Remove the rotating locking jaw.

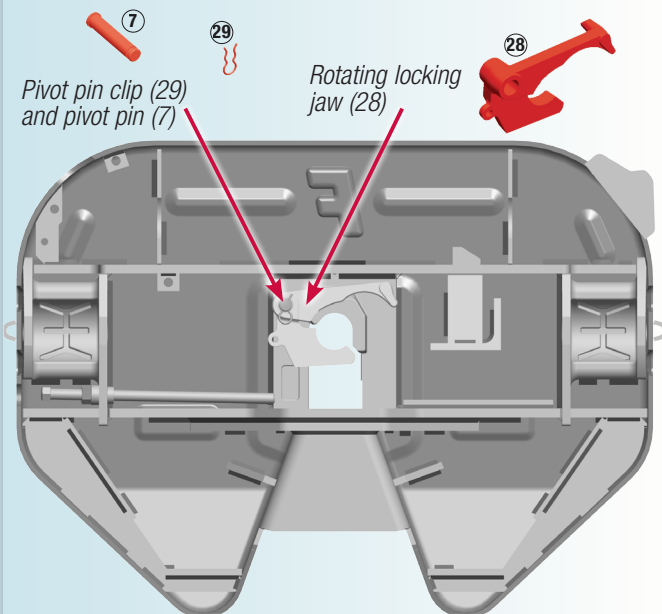

Refer to exploded view of assembly on page 4 to identify item number and parts.

## 1. Inspect fifth wheel for damage

Inspect the fifth wheel for damage in areas that prevent the proper operation of locking components. Inspection should include but not limited to; the stationary jaw, lock bar, cover plate, wedge guide and operating handle

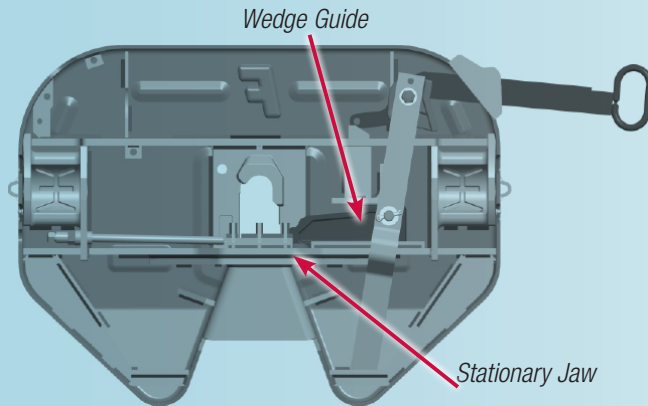

*Before rebuilding the assembly, check to make sure that there are no cracks in the crossmembers or other components. Also check bracket pin holes to ensure they are not overly worn (pins should fit snugly). Refer to exploded view of assembly on page 18 to identify item numbers and parts.*

**Adequate lubrication should be used**

## 2. Insert rotating locking jaw

Insert the rotating jaw (item 28) after applying a light coating of grease. Note: Insert the jaw so that the hole in the cover plate lines up with the hole in the rotating jaw. Raise the fifth wheel and then insert the long pivot pin (item 7) into the fifth wheel and then into the rotating jaw. Note: Make sure the notched portion of the pivot pin is inserted into the fifth wheel first. Secure the pivot pin in place with a new pivot pin clip (item 29).

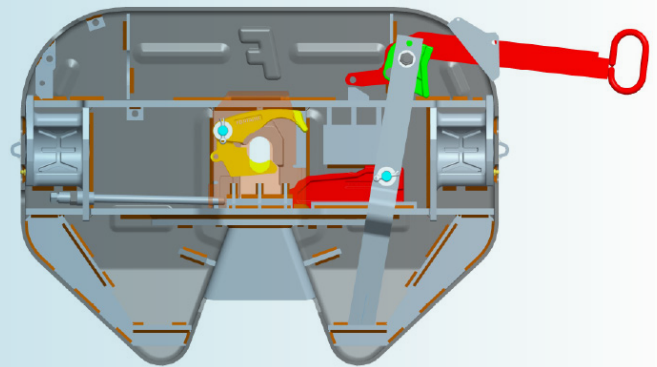

## 3. Attach springs

Make sure the fifth wheel is completely closed. Attach the jaw spring (item 27) to the rotating locking jaw. Now install main spring (item 26) to the pull handle. Now install the main spring (item 26) to the operating handle.

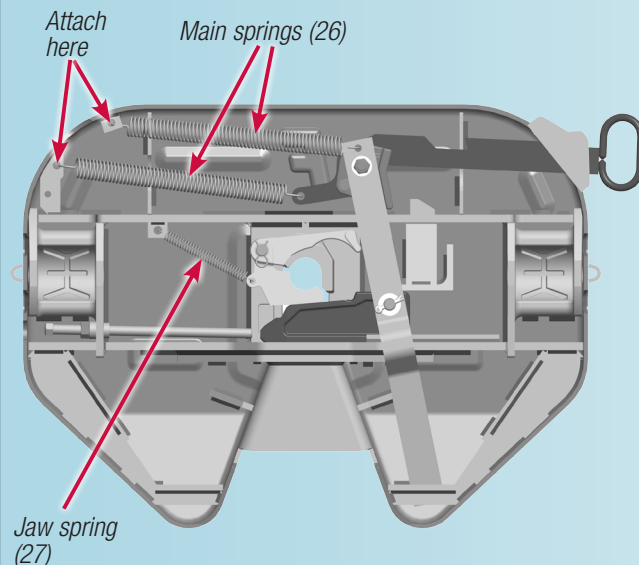

## 4. Adjust fifth wheel

Open the fifth wheel, insert a 2" kingpin and close the wheel. Turn the adjustment rod (item 1) clockwise (inward) until it contacts the end of the locking wedge. Now turn the adjustment rod clockwise (inward) an additional 2-1/2 complete revolutions. This will give the recommended 0.525 mm (.02") running clearance. Tighten the adjuster rod jam nut (item 2). The fifth wheel should operate freely and smoothly without binding or interference.

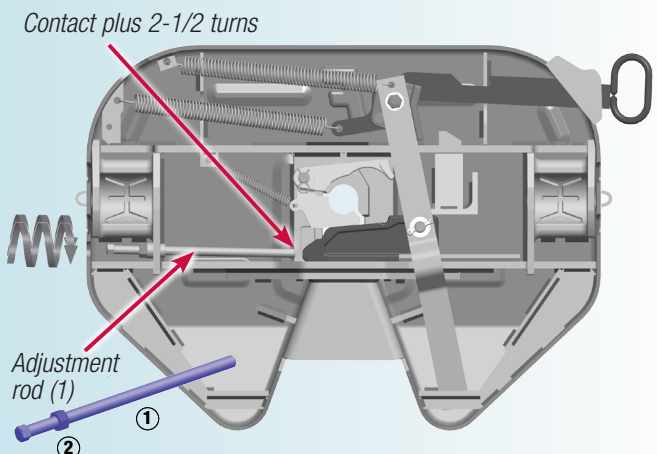

# Ultra LT rebuild diagram

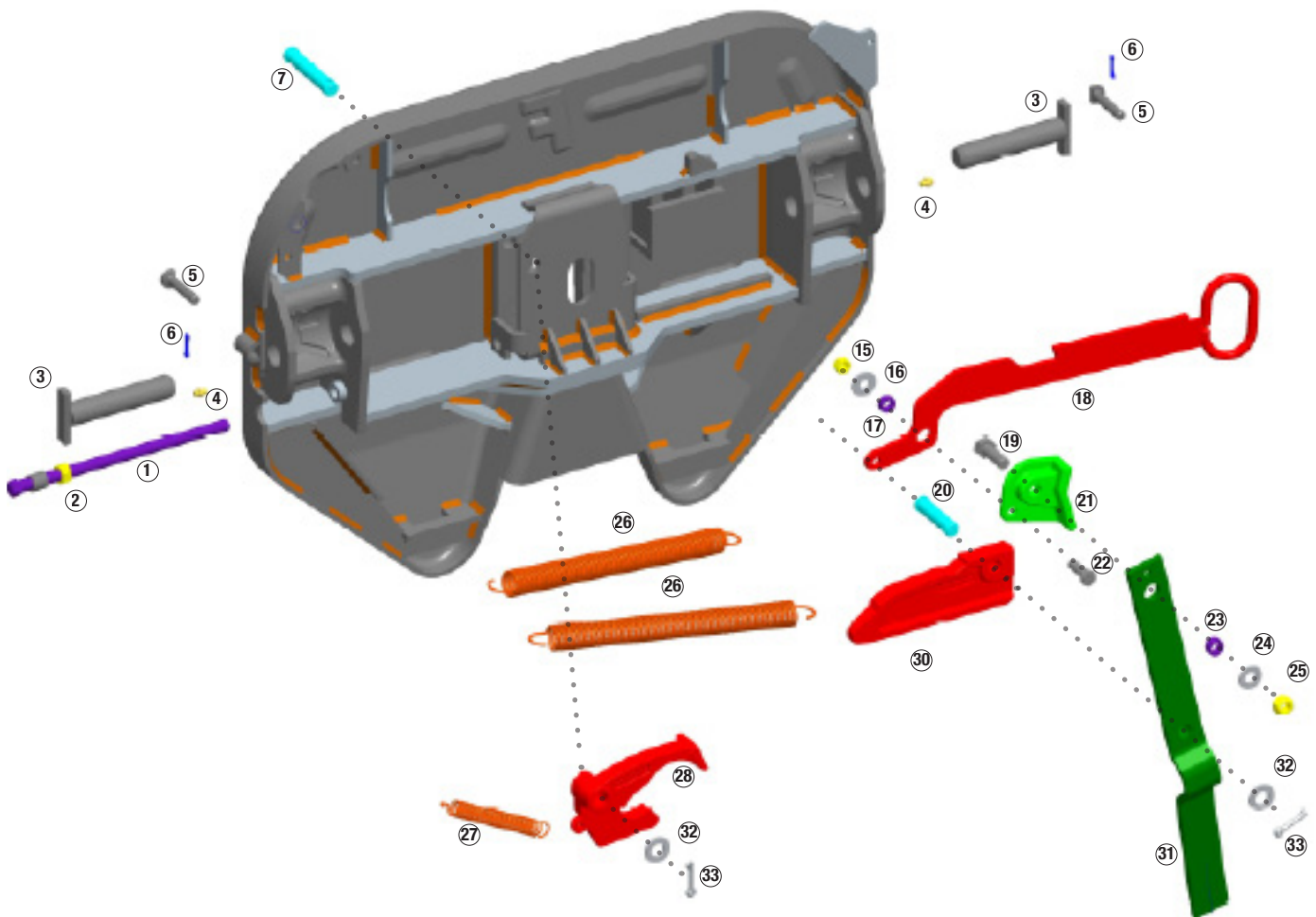

Repair kit (KIT-RPR-UL-L)		
Item	Description	Quantity
⑦	Pivot pin, long	1
⑳	Pivot pin, short	1
㉕	Lock nut, 5/8"-11	1
㉖	Main spring	2
㉗	Jaw spring	1
㉘	Rotating locking jaw	1
㉙	Pivot pin clip	2
㉚	Locking wedge	1
㉛	Washer, 3/4"	2
㉜	Cotter Pin	2

Spring kit (KIT-SPR-ULHH)		
㉖	Main spring	2
㉗	Jaw spring	1

Adjuster rod kit (KIT-ROD-UL)		
①	Adjustment rod	1
②	Adjustment rod nut	1

Secondary lock kit (KIT-SEC-ULHH-L)		
Item	Description	Quantity
⑮	Lock nut, 1/2"-13	1
⑯	Washer, 1/2"	1
⑰	Bushing, 5/16"	1
⑲	Hex head bolt, 5/8"-11 x 1.75"	1
㉑	Secondary lock	1
㉒	Hex head bolt, 1/2"-13 x 1.5"	1
㉓	Spacer bushing	1
㉔	Washer, flat 5/8"	1
㉕	Lock nut, 5/8"-11	1

Operating lever kit (KIT-OPR-UL)		
⑲	Hex head bolt, 5/8"-11 x 1.75"	1
⑳	Pivot pin, short	1
㉓	Spacer bushing	1
㉔	Washer, flat 5/8"	1
㉕	Lock nut, 5/8"-11	1
㉛	Operating handle	1
㉛	Washer, 3/4"	1
㉜	Cotter Pin	1

Mounting pin kit (KIT-PIN-UL)		
Item	Description	Quantity
③	Bracket pin	2
⑤	Bracket retainer pin	2
⑥	Cotter pin	2
	Bracket bushing (not pictured)	2

Pull handle kit (KIT-PUL-UL-L)		
⑮	Lock nut, 1/2"-13	1
⑯	Washer, 1/2"	1
⑰	Bushing, 5/16"	1
⑱	Pull handle	1
㉒	Hex head bolt, 1/2"-13 x 1.5"	1



# Ultra LT rebuild diagram key

Item	Description	Quantity
①	Adjustment rod	1
②	Adjustment rod nut	1
	Adjuster Stud Spacer	1
③	Bracket pin	2
④	Grease fitting	2
⑤	Bracket retainer pin	2
⑥	Cotter pin	2
	Bracket bushing (not pictured)	2
⑦	Pivot pin, long	1
⑮	Lock nut, 1/2"-13	1
⑯	Washer, 1/2"	1
⑰	Bushing, 5/16"	1
⑱	Pull handle	1
⑲	Hex head bolt, 5/8"-11 x 1.75"	1
⑳	Pivot pin, short	1
㉑	Secondary lock	1
㉒	Hex head bolt, 1/2"-13 x 1.5"	1
㉓	Spacer bushing	1
㉔	Washer, flat 5/8"	1
㉕	Lock nut, 5/8"-11	1
㉖	Main spring	1
㉗	Jaw spring	1
㉘	Rotating locking jaw	1
㉙	Pivot pin clip	1
㉚	Locking wedge	1
㉛	Operating handle	1
㉜	Washer, 3/4"	2
㉝	Cotter Pin	2







[www.fifthwheel.com](http://www.fifthwheel.com)